

TITANIUM-SUBLIMATION PUMP CONTROLLER MODEL TSP2

The AML Titanium Sublimation Pump Controller regulates the quantity of material sublimated from the filaments, compensating for changing conditions and eliminating the need for operator attendance or adjustment.

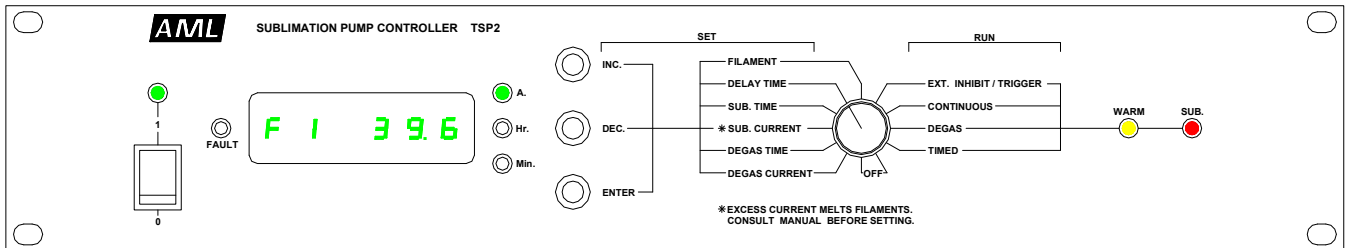

- ◆ 2U (88mm) high full-width instrument for easy rack-mounting.
- ◆ Low cost. Simple, robust and reliable design, which is easy to service. All output switching is by semiconductor devices.
- ◆ Low-noise. Complies with EC EMC and LV Directives. Power factor >0.97.
- ◆ Sublimation current settable over the range 30 to 55A in increments of 0.1A. Suits 85% Ti, 15% Mo filaments from 1.8 to 2.1mm diameter.
- ◆ Filaments are warmed and cooled gently to avoid thermal shocks. The sublimation current contains minimal harmonics to reduce the risk of early filament failure due to magnetostrictive stress or mechanical resonance.
- ◆ Pump current is accurately regulated in order to automatically compensate for mains variations and pump cables warming.
- ◆ No in-service adjustment is required.
- ◆ Self-timed delay between getter renewal adjustable from 1 minute to 9.9 hours.
- ◆ Filaments may be run for degassing at currents between 5 and 25A to prevent overloading the ion pump. Filaments can be kept warm at the end of a system bake.
- ◆ Sublimation inhibit/trigger function by external switch or relay.
- ◆ Suitable for a wide range of cartridges with up to 4 filaments.
- ◆ Indicates open-circuit filament, shorted cable/filament, inhibit, overtemperature. Thermal overload protection.

This document and the designs depicted are the copyright of Arun Microelectronics Ltd. Specifications are subject to change, confirm before ordering. E & OE. AML acknowledges the rights of the owners of all trademarks and registered names.

AML

innovation in vacuum technology

SPECIFICATION

Dimensions:	
Width	483mm
Depth	365.2mm
Height	88mm
TSP2 weight	11kg
TSP2 shipping weight	13kg
TSP2L6 weight	2.5kg
Dimensions are nominal, weights approximate.	

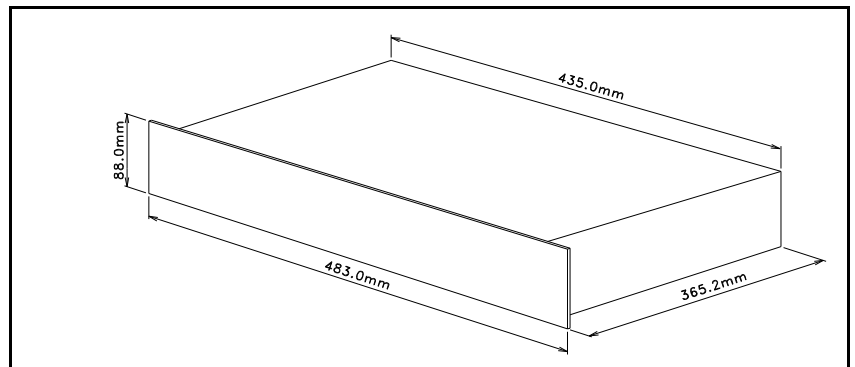

Operating Temperature:	10 to 40°C for rated performance. Operation up to 50°C is possible at longer sublimation intervals, i.e. below 10 ⁻⁶ millibar.
Supply Voltage:	100/110V (Option L) OR 220/230V RMS (Option H) 50 or 60Hz, to order.
Power Consumption:	Less than 20 watts when idling, less than 700 watts when sublimating at 55A with a maximum-length cable.
Power Factor:	> 0.97 at maximum output power.
Output Current:	Regulated at 30 to 55A RMS x 0.1A in sublimation, 5 to 25A RMS x 5A in degas.
Output Voltage:	The output voltage is determined by the lead and cartridge resistance. Maximum output voltage is ≥9.5 V RMS at 45A.
Timing:	Sublimation period 0.1 to 3 minutes x 0.1 min.. Delay interval 1 to 59 minutes, 1 to 9.9 hours. Degas time 1 to 99 minutes. All timing is derived from the mains supply frequency.
Output Duty Cycle:	100% at 300w output power and less than 30°C ambient temperature.
AML pursues a policy of continuous product improvement and reserves the right to make detail changes to specifications without consultation. Unless otherwise stated all specifications are typical and at 25° Celsius. E and OE.	

Ordering information: **TSP2** Titanium Sublimation Pump Controller
add suffix **H** for 220/240 volt mains supply
add suffix **L** for 100/110 volt mains supply

TSP2L6 6 metre non-bakeable pump lead
TSP2BL6 6 metre pump lead with 1 metre 200°C-bakeable section

